



Actual Size



Sidekiq™ Stretch

Wideband RF transceiver + FPGA, GPS and integrated pre-select filters

POCKET-SIZED SDR WITH FILTERS AND GPS

COMPATIBLE WITH MILLIONS OF COMPUTER SYSTEMS

The Sidekiq Stretch is a highly-integrated and highly compatible RF powerhouse in the Sidekiq product family. Packing the hardware that would traditionally require three separate cards into a single, small form factor radio module, the embeddable Stretch uses Analog Devices' AD9361 RFIC for high performance and flexibility, and adds both a GPS disciplined oscillator (GPSDO) for excellent long-term positioning accuracy and tunable Rx pre-select filtering for optimum interference protection. These and other integrated features create a complete, high performance, low latency, wideband transceiver in an M.2 2280 card. In this form factor, Sidekiq Stretch can be used in millions of host devices where a PCIe-based NVMe® solid state drive (SSD) is supported. Its small size, high compatibility, and high level of performance radically simplifies product development and makes Sidekiq Stretch an ideal choice for use anywhere where low size, weight, and power (SWaP) are critical.

The Sidekiq Stretch is offered in two form factors:

- Standard Sidekiq Stretch (22mm x 80mm) card. This card with B+M keying is ready for integration into a host computing device with a compatible M.2 2280 slot.
- Thunderbolt 3 (TB3) Platform. A standard Sidekiq Stretch card integrated into a TB3 carrier with a small enclosure that provides SMA ports for RF, and a TB3 compatible USB-C connector for both power and connectivity to the host.

Use Sidekiq Stretch with the Sidekiq Platform Development Kit (PDK)*. PDK users can access both a software API for interfacing to the card, as well as the source code for the FPGA reference design for customization. The software API provides an easy-to-use interface for configuring the RF transceivers and streaming data between the host and Sidekiq Stretch over the PCIe interface. Advanced users can add their own processing blocks to the FPGA to significantly increase the signal processing capabilities of the system.

* Platform Development Kit (PDK) required for initial purchase.



Sidekiq Stretch in TB3 Chassis

BLOCK DIAGRAM

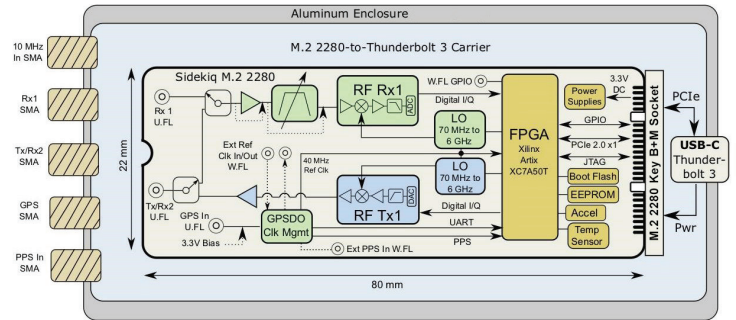

Card inside TB3 chassis shown.

RF SPECIFICATION

RF INTERFACE

- Antenna Port 1: U.FL coaxial connector supporting Rx
- Antenna Port 2: U.FL coaxial connector supporting either Tx or Rx

RF TUNING RANGE

- 70 MHz to 6 GHz (RF access to 45 MHz)

RF CHANNEL BANDWIDTH

- Up to 50 MHz

TYPICAL RX NOISE FIGURE

- < 8 dB

TYPICAL RX IIP3

- -10 dBm

RX AND TX SAMPLE RATES RANGE

- 233 Ksamples/sec to 61.44 Msamples/sec

A/D AND D/A CONVERTER SAMPLE WIDTH

- 12-bits

RX GAIN RANGE

- 0-76 dB, 1 dB steps

TX GAIN RANGE

- 0-89 dB, 0.5 dB steps

TYPICAL TX OUTPUT POWER

- +10 dBm (+13 dBm < 2 GHz)

GPS

- NMEA sentences, PPS output, and frequency-disciplining
- Multi-channel GPS and GLONASS/BEIDOU, SBAS, QZSS overlay systems receiver
- U.FL antenna input, 3.3V bias for active GPS antenna

EXTERNAL CLOCK REFERENCE

- W.FL coaxial input, configurable for 10 MHz or 40 MHz input clock
- W.FL coaxial output, 40 MHz signal suitable to drive another Sidekiq module

EXTERNAL PPS

- W.FL coaxial input

DIGITAL SPECIFICATION

FPGA

- Xilinx Artix 7 XC7A50T FPGA with x1 Gen2 PCIe interface to host

FPGA REPROGRAMMING

- Over PCIe (supports partial reconfiguration as well as reprogramming of FPGA boot flash)

GPIO

- Available at M.2 edge connector; one GPIO available on a W.FL connector

COMPONENT TEMPERATURE RANGE

- -40 deg C to +85 deg C

TEMPERATURE SENSOR

- -55 deg C to +125 deg C (+/- 2 deg C)

MOTION TRACKING

- 6-axis, combining a 3-axis gyroscope and 3-axis accelerometer

PHYSICAL SPECIFICATION

DIMENSIONS

- 22mm x 80mm x 4.5mm

WEIGHT

- 9.07g

TYPICAL POWER CONSUMPTION

- 2.5W

RX PRE-SELECT FILTERING

- Allows for flexible bandpass covering 50 MHz to 6 GHz

THUNDERBOLT 3 PLATFORM SPECIFICATION

DIMENSIONS

- 63.5mm x 136.2mm x 12.7mm

WEIGHT

- 180g

POWER CONSUMPTION

- 3W

RF INTERFACE

- SMA RF connectors for TX/RX, RX, CLK Reference, PPS, GPS

INTERFACE TO HOST

- Thunderbolt 3 over locking USB-C connector (provides both power and data transport)

Specifications subject to change without notice.

Epiq Solutions is a business dedicated to advancing RF technology through products designed and manufactured in the U.S.A.

Epiq Solutions exports its products strictly in accordance with all US Export Control laws and regulations which shall apply to any purchase or order.



Rev 1.2 17th December, 2025