

**1. Downconverter** takes a section of spectrum and shifts it all to a lower band

**2. RF Front End** varies widely in sophistication from the integrated filtering in an integrated RFIC to extremely high-performance superheterodyne architectures containing thousands of components.

**3.** A **tuner** selects and conditions a signal before passing it on as an analog IF signal. Can include filtering, gain control etc. all in the analog RF domain.

**4.** **Streaming radios** include digitization and output in standard digital formats such as VITA 49. They often have Digital Down Converters (DDCs) that can convert, filter and reduce the amount of digital data output. Frequently not designed to be user-customizable.

**5.** **SDRs** can process digital data on-board using an FPGA. Useful for latency-sensitive applications where a radio is required to process signals in with clock cycle accuracy. Some SDRs have FPGA resources that are customer-accessible.

**6.** These SDRs integrate a processor that can run an operating system and application, allowing standalone operation.

**7.** GPU to allow applications such as AI signal classification to be run entirely at the edge.

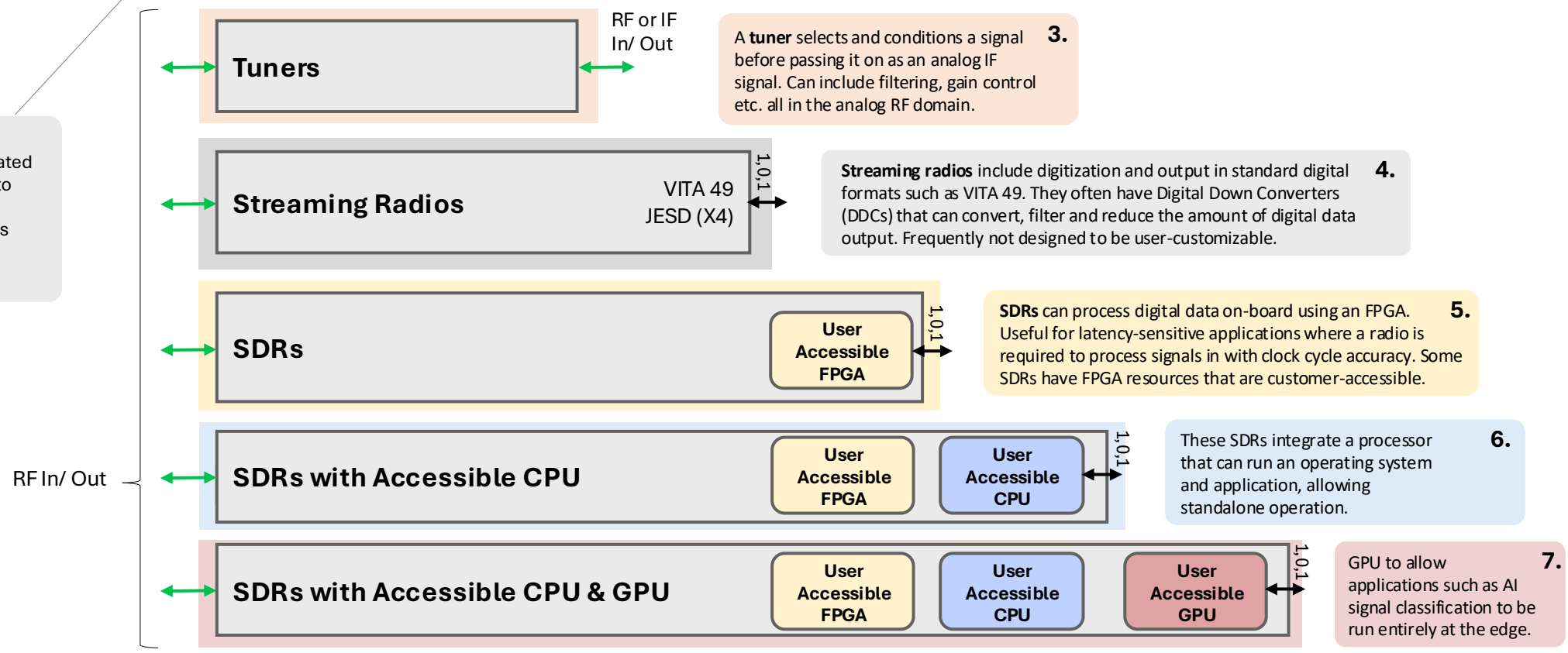

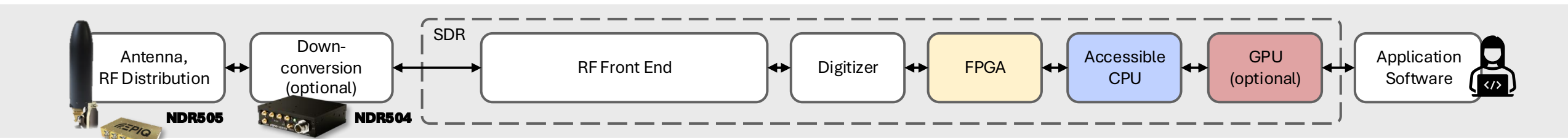

**Tuners**

Products: NDR888, VPX410, NDR585

**Streaming Radios**

Products: NDR818, NDR358, NDR551, NDR562, VITA 49 JESD (X4), Sidekiq NV800\*, NDR364, NDR318, NDR374, Sidekiq X4\*\*

**SDRs**

Products: Sidekiq NV100, VPX400, Sidekiq MiniPCle, Sidekiq M.2, Sidekiq NVM2, Sidekiq Stretch

Capabilities: User Accessible FPGA

**SDRs with Accessible CPU**

Products: Matchstiq Z4 (NEW), Matchstiq Z3u, Matchstiq Z2, Sidekiq Z2, NDR325#, Matchstiq V40 (NEW)

Capabilities: User Accessible FPGA, User Accessible CPU

**SDRs with Accessible CPU & GPU**

Products: Matchstiq G20/40, Matchstiq X40

Capabilities: User Accessible FPGA, User Accessible CPU, User Accessible GPU

Consistent Software API: Libsidekiq PDK

# NDR325 is not supported by Libsidekiq

\* NV800 can act as a VITA 49 streaming radio but also offers the flexibility to customize an accessible FPGA through a PDK. \*\* X4 is frequently supplied on a carrier card which includes an FPGA, (Sidekiq X4 PCIe blade) so in that form it would then be classed as a full SDR.